



**Lindec®
LCPS**

Art. no. LCPS, LCPSC

**COMPOUND SPRAYER
WITH DIAPHRAGM PUMP**



LCPS shown with optional Push Cart
LCPSC



AB Lindec® power sprayer are a powerful and durable sprayer, driven by a 5,5 Hp petrol engine and are most suitable for applying sealers and curing products.

Product details

The sprayer can be installed directly on a 200 liter drum or our special build sprayer cart, where you also can put the bigger drum for easy movement on the construction site. The sprayer is sold separately or together with the cart. The sprayer includes a 20 m (67 ft) long and durable hose with a heavy duty sprayer handle. All hoses are connected with a "quick connecting coupling" to make work easier and quicker

Semi-hydraulic two-diaphragm pump, for use in the semi-professional construction sectors. Cart-mounted in combination with internal combustion 5,5 Hp petrol engine sprayers for pressure pesticide treatments on floors. Parts in contact with pumped liquids in Rilsan-coated aluminum, and AISI 303/304. Diaphragms in BlueFlex™. Seals in NBR. Die-cast casing with oil-immersed mechanism, fitted with air-hydraulic damper for smoother operation and less hammer effect in the delivery circuit. Oil drainage stopper. Pistons with ring for a more efficient "oil cushion" system to protect the diaphragm. New-design diaphragm cut-out system to prevent contact tearing even in heavy-duty operating conditions. Spherical sector profile valves for lower flow resistance Reduction gearboxes for internal combustion engines.

Lindec® LCPS

Pump technical specifications

Diaphragms	2
Max flow (lpm)	36.2
Max flow (gpm)	9.6
Max Pressure (bar)	40
Max Pressure (psi)	580
Power (Hp)	5,5
RPM	550
Suction (mm)	ø 30
Outlet (mm)	2 x ø 10
Max temperature (°C)	60

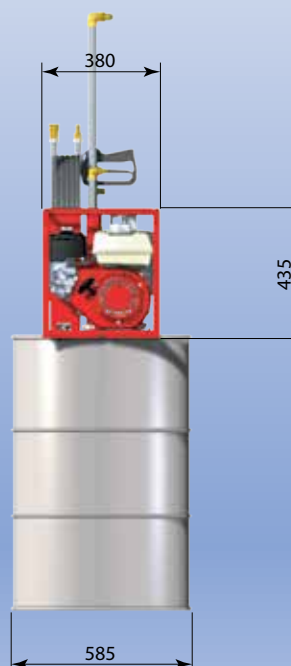
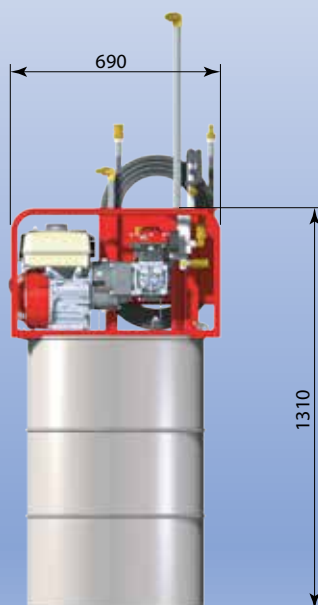
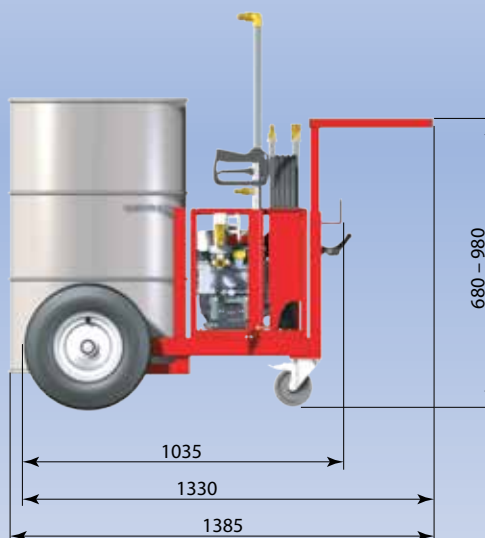
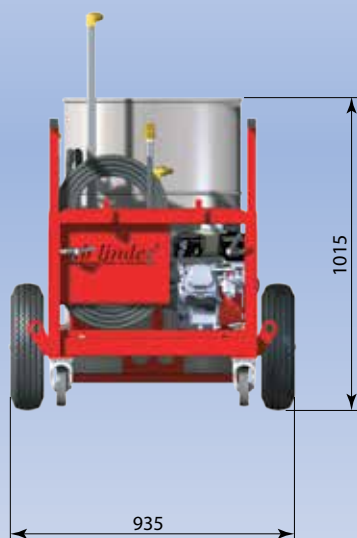

ab lindec® endeavours to provide correct information about technical properties and handling of its products. However, while ab lindec® has no control over the way in which the products are mixed and laid, or the conditions under which they set, ab lindec® can in no way be held responsible. ab lindec® is only responsible for the quality of the products at the time of delivery.